



DC MOTOR

12 watt

Graphite Brushes

2-40/12 \_ \_

TRIDENT ENGINEERING LIMITED  
 Trident House, King Street Lane,  
 Winnersh, Wokingham,  
 Berkshire, RG41 5AS

Telephone: 0118 978 6444  
 Fax: 0118 977 6345  
 Email: sales@tridenteng.co.uk  
 www.tridenteng.co.uk

Stock Voltages		12	15	18	24	30
1. Nominal voltage	Volt	12	15	18	24	30
2. No-load speed	rpm	5280	5180	5230	5280	5180
3. No-load current	mA	50	39	33	25	19
4. Nominal Torque	mNm	26	26	26	26	26
5. Starting torque	mNm	121	123	126	123	125
6. Torque constant	mNm/A	21.5	27.4	32.6	43.0	54.9
7. Nominal Speed	rpm	4140	4100	4150	4170	4100
8. Nominal Current	mA	1250	980	830	630	490
9. Terminal Resistance	Ohm	2.1	3.3	4.6	8.3	13.1
10. Rotor Inductance	mH	0.31	0.50	0.71	1.23	2.01
11. Rotor Moment of Inertia	kgm <sup>2</sup>	4x10 <sup>-6</sup>	4x10 <sup>-6</sup>	4x10 <sup>-6</sup>	4x10 <sup>-6</sup>	4x10 <sup>-6</sup>
12. Mechanical time constant	ms	18	18	18	18	18
13. Ambient temp. range operating	-10/+60 °C					
14. Thermal resistance winding-housing	K/W	5.5	5.5	5.5	5.5	5.5
15. Weight	gram	200				
16. Bearings type		sleeve + ball				

Product combinations

Gearheads GS38, GS40

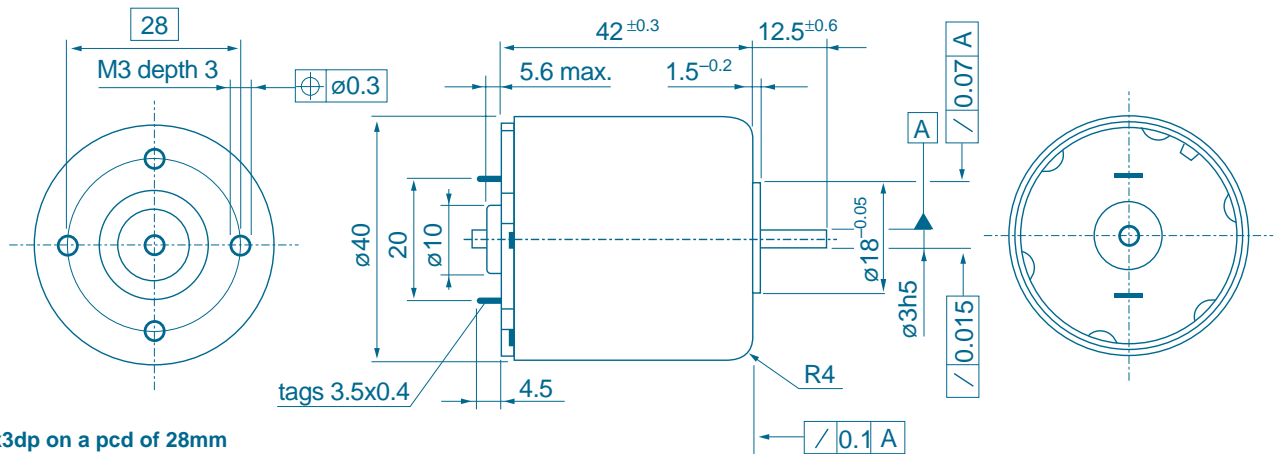

M3x3dp on a pcd of 28mm

Notes

